

MASTER®

CASE STUDY #1013

External Cylindrical Grinding Machine

Workpiece:	Flange
Operation:	OD Grinding
Machine:	Micromatic e-Grind 200 CNC
Cycle Time:	28 secs
Stock Removal:	0.2mm
Hardness:	Dia 1: 55 ~ 60 HRC Dia 2: 18 ~ 25 HRC
CpK:	5.295 (for tolerance of 0.020mm)
Run out W.R.T centre:	0.005mm
Surface Roughness (Lead free):	0.46 µm Ra, R-max 4.33
Dressing Skip:	5 Components

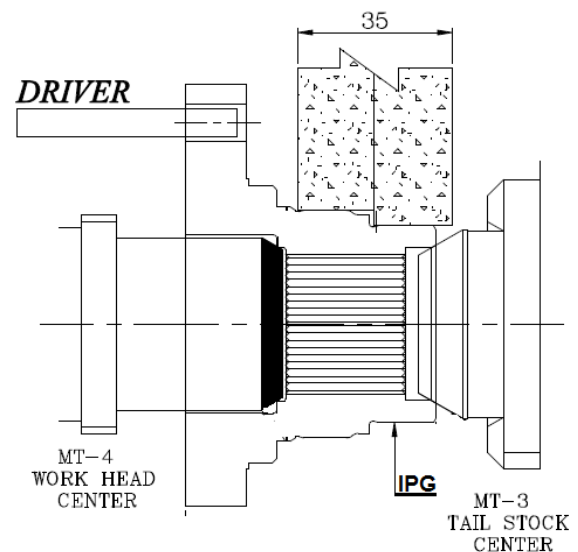

SOLUTIONS FOR INDUSTRY

T: 01327 703813
sales@master-abrasives.co.uk

 @MasterAbrasive
www.master-abrasives.co.uk