

# MASTER®

## CASE STUDY #1037

### Special Purpose Grinding Machine

<b>Workpiece:</b>	<b>Grinding of Eccentric Shaft (utilization of Manual Fixture)</b>
<b>Size Variation:</b>	< 0.002mm
<b>Taper on OD:</b>	< 0.003mm
<b>Eccentricity:</b>	< ± 0.004mm
<b>Surface Finish:</b>	0.2 $\mu$ Ra
<b>Uniqueness of solution:</b>	<ul style="list-style-type: none"><li>• Economic</li><li>• Easy and quick set-up change</li><li>• Less part; easy to maintain</li></ul>

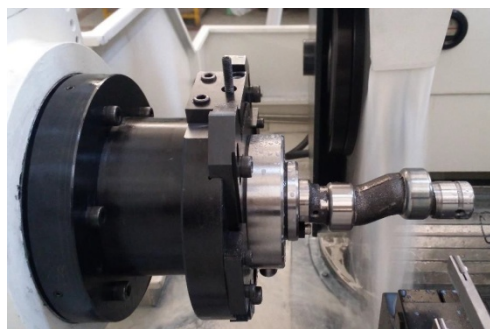
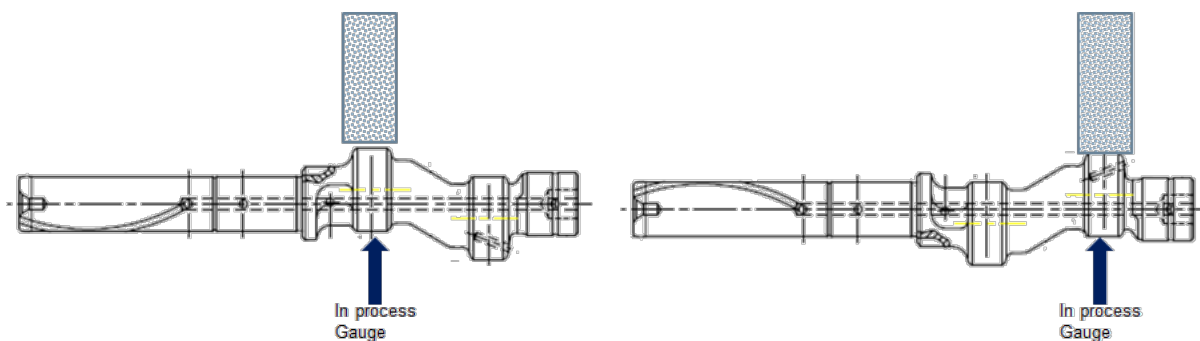

**SOLUTIONS FOR INDUSTRY**

T: 01327 703813  
sales@master-abrasives.co.uk

 @MasterAbrasive  
www.master-abrasives.co.uk