



SUPERFINISH

INNOVATION

μ

modular • flexible • economical • universal

Bandfinisher KG50



Technology-benefits

The optimized surface produces less friction and therefore improves the wearing, the durability, the noise development and the energy expenditure.

This kind of surface improvement is simple – compared to other principles – process-safe and economical.

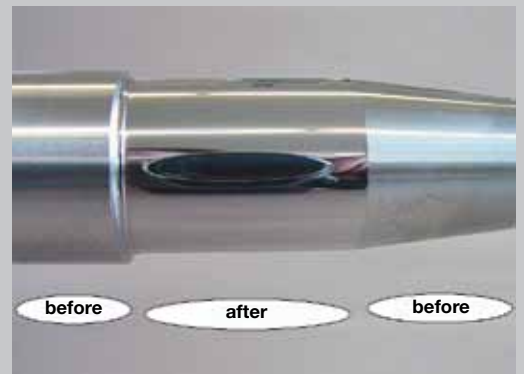

SBM control box manual
for manual finishing of individual parts and small series



SBA control box automatic
for time-regulated cut-in-finishing of individual parts and small series

Bandfinisher KG50 – Technical datas

Oscillation rate:	300 – 1400 strokes/min.
Oscillation path:	Standard +/- 1 mm optional : +/- 0,5; +/- 1,5; +/- 2 mm
Automated tape feed:	10 – 100 mm/min.
Pressing-on move:	Standard 40 mm; optional : 70, 100 mm
Pressing-on force:	50 – 300 N (1 – 6 bar); optional: 80 – 480 N
Pressing-on roll:	max. 50 mm, one-sided arranged bearing
Pressing-on roll hardness:	Standard 65 ShA; optional: 35, 50, 90 ShA
Control voltage:	24 VDC
Weight:	14,5 kg

Anschlüsse

Electric:	100 – 260 VAC, 50/60 Hz, 6 A (L, N, PE)
Pneumatic:	1 x 6 bar

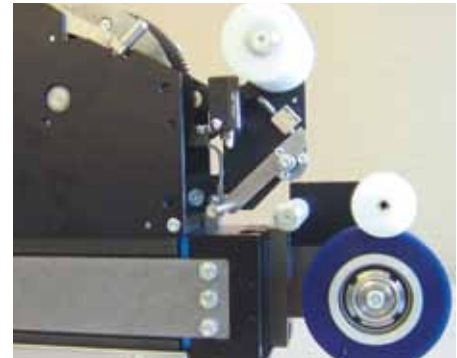

Options

- Machine device for direct assembly with sensors
- Special pressing-on roll

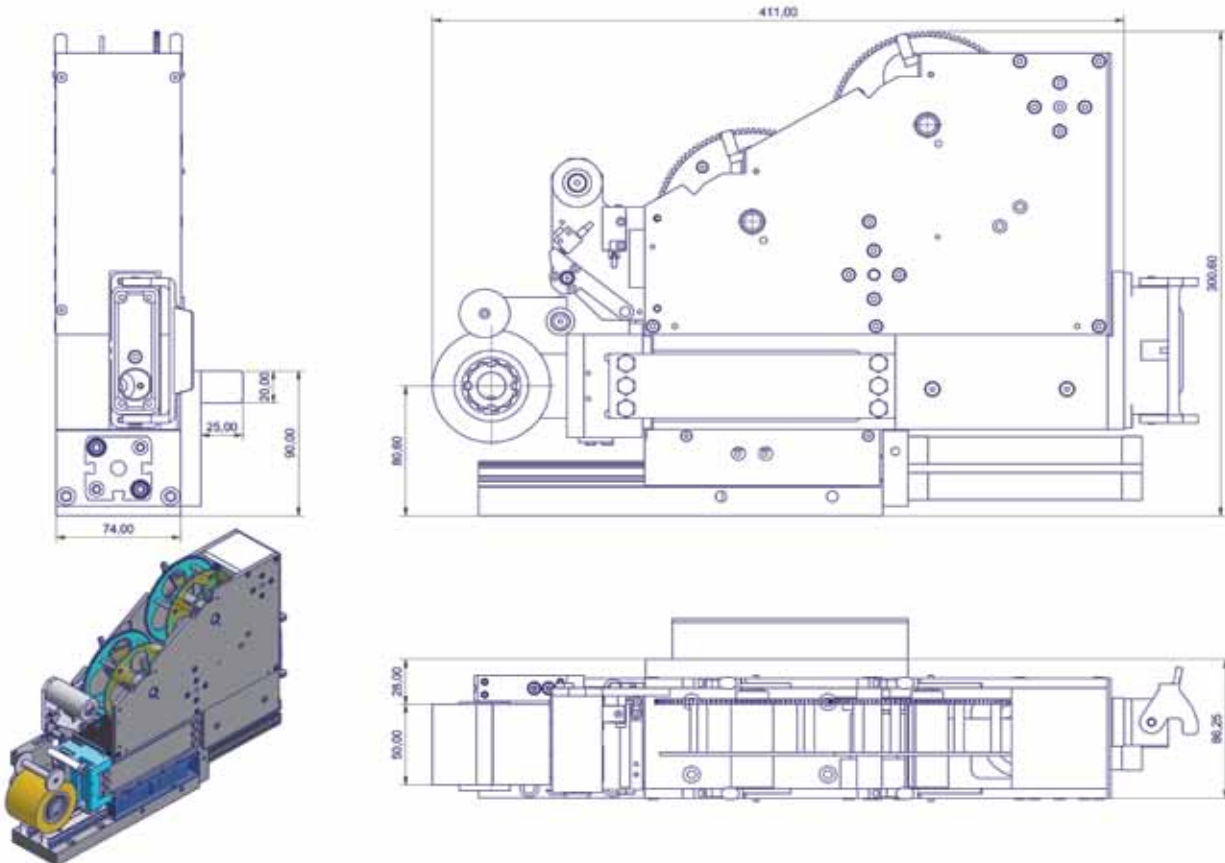

SUPERFINISH – a company of Thielenhaus Technologies

UK & Ireland Agent

MASTER
ABRASIVES

Phone: 01327 703813
Email: sales@master-abrasives.co.uk
www.master-abrasives.co.uk



Superfinish Innovation AG
St. Gallerstrasse 52
CH-9548 Matzingen
Phone: +41 (0)52 376 26 20
info@superfinish.ch
www.superfinish.ch