

SUPERFINISH

INNOVATION

μ

modular • flexible • economical • universal

Bandfinisher KG50-100M

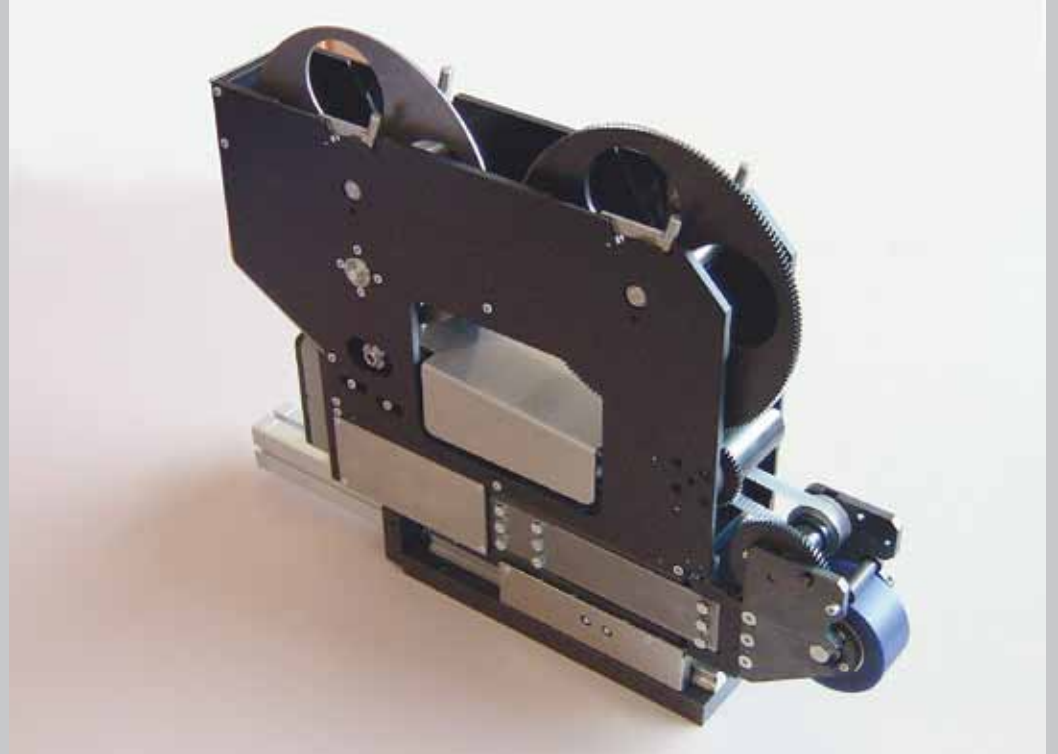

Technology-benefits

The optimized surface produces less friction and therefore improves the wearing, the durability, the noise development and the energy expenditure.

This kind of surface improvement is simple – compared to other principles – process-safe and economical.

The Bandfinisher KG50-100M is made for the finishing of big series.

The driven pressing-on roll allows the finishing in both rotation directions and guarantees always the constant tapefeed-speed.

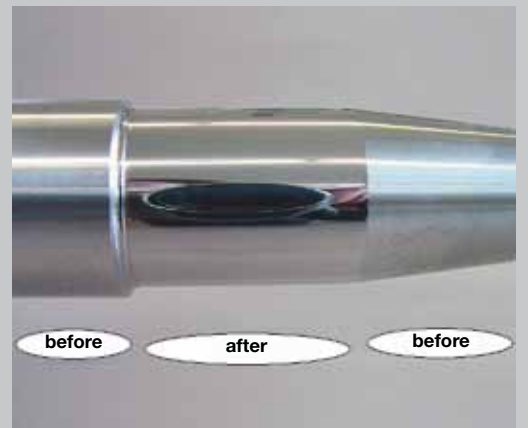

Bandfinisher KG50-100M – Technical datas

Oscillation rate:	300 – 1400 strokes/min.
Oscillation path:	Standard +/- 1 mm optional: +/- 0,5; +/- 1,5; +/- 2 mm
Automated tape feed:	10 – 100 mm/min.
Tape length:	100 m
Pressing-on move:	Standard 40 mm; optional: 70, 100 mm
Pressing-on force:	50 – 300 N (1 – 6 bar); optional: 80 – 480 N
Pressing-on roll:	max. 35 mm, driven
Pressing-on roll hardness:	Standard 65 ShA; optional: 35, 50, 90 ShA
Control voltage:	24 VDC
Weight:	16,5 kg



Adaptors

Elektric:	Connection to Industrial adapter
Needed Controller:	maxon DECS50/5; 343253; 3x; maxon DEC50/5; 230572; 1x
Pneumatic:	Connection to valve, 2 x 6 bar

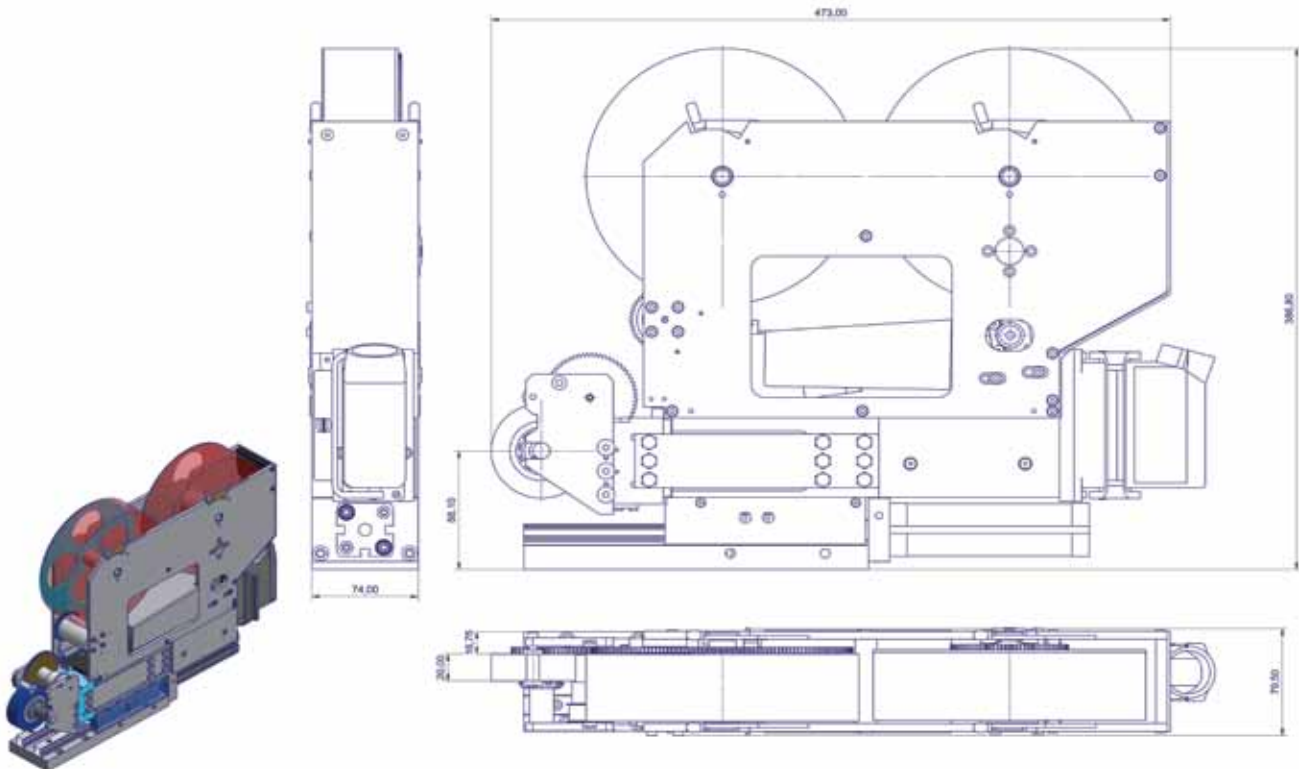

SUPERFINISH – a company of Thielenhaus Technologies

UK & Ireland Agent

MASTER
ABRASIVES

Phone: 01327 703813
 Email: sales@master-abrasives.co.uk
 www.master-abrasives.co.uk



Superfinish Innovation AG
 St. Gallerstrasse 52
 CH-9548 Matzingen
 Phone: +41 (0)52 376 26 20
 info@superfinish.ch
 www.superfinish.ch