

# SUPERFINISH

INNOVATION

μ

modular • flexible • economical • universal

## Bandfinisher KG50-DB

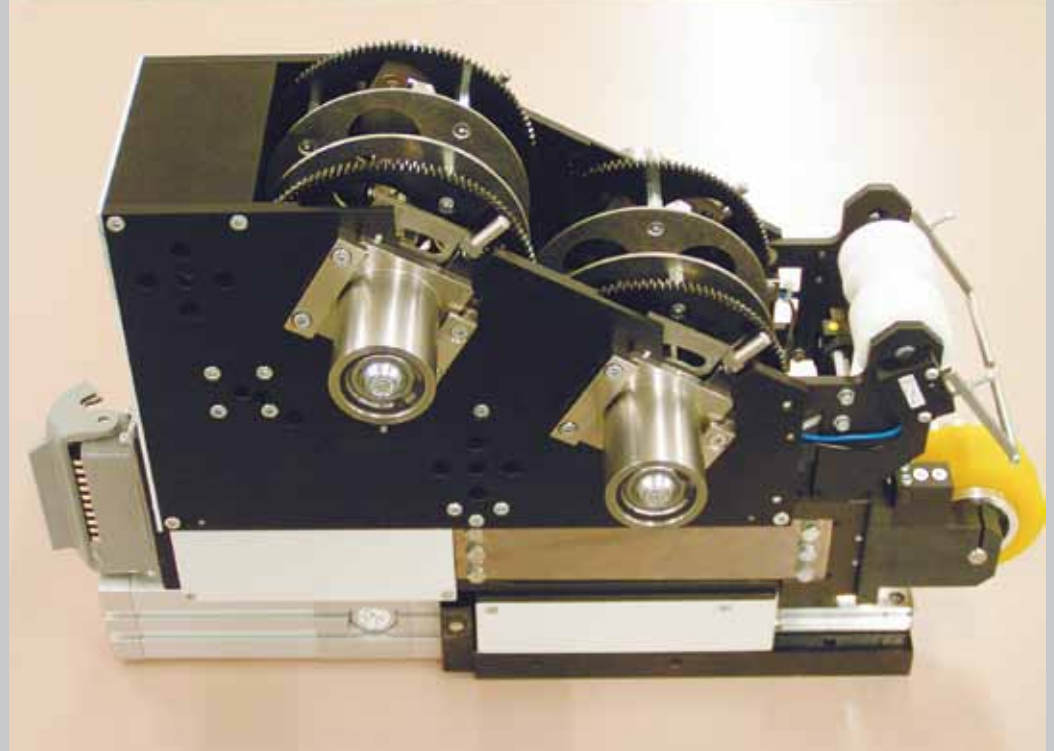

### Technology-benefits

The optimized surface produces less friction and therefore improves the wearing, the durability, the noise development and the energy expenditure.

This kind of surface improvement is simple – compared to other principles – process-safe and economical.

The Bandfinisher KG50-DB is a double-tape-device which can finish two back-to-back positioned parts at the same time.

The diameters of the parts can be different. Each Finishband can be feded with different speed.

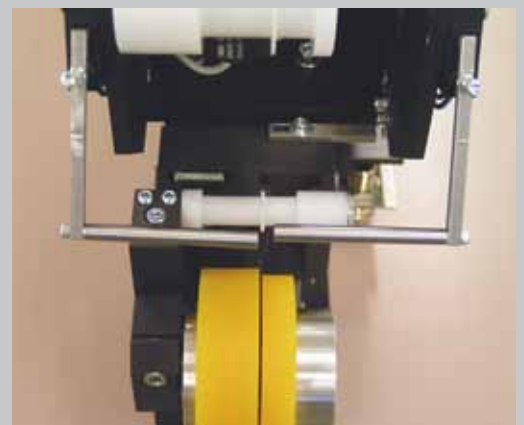
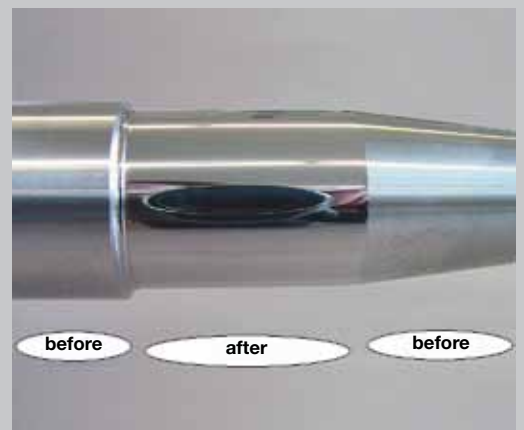

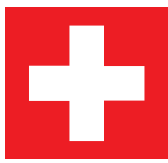

## Bandfinisher KG50-DB – Technical datas

Oscillation rate:	300 – 1400 strokes/min.
Oscillation path:	Standard +/- 1 mm optional: +/- 0,5; +/- 1,5; +/- 2 mm
Automated tape feed:	2 x 10 – 100 mm/min.
Pressing-on move:	Standard 40 mm; optional: 70, 100 mm
Pressing-on force:	50 – 300 N (1 – 6 bar); optional: 80 – 480 N
Pressing-on roll:	max. 2 x 25 mm, one-sided arranged bearing
Pressing-on roll hardness:	Standard 65 ShA; optional: 35, 50, 90 ShA
Control voltage:	24 VDC
Weight:	16,5 kg



### Adaptors

Elektric:	Connection to Industrial adapter
Needed Controller	maxon DECS50/5; 343253; 3x
Pneumatic:	Connection to valve, 2 x 6 bar

### Options

- Clampingcylinder for vertical built in
- div. control sensors

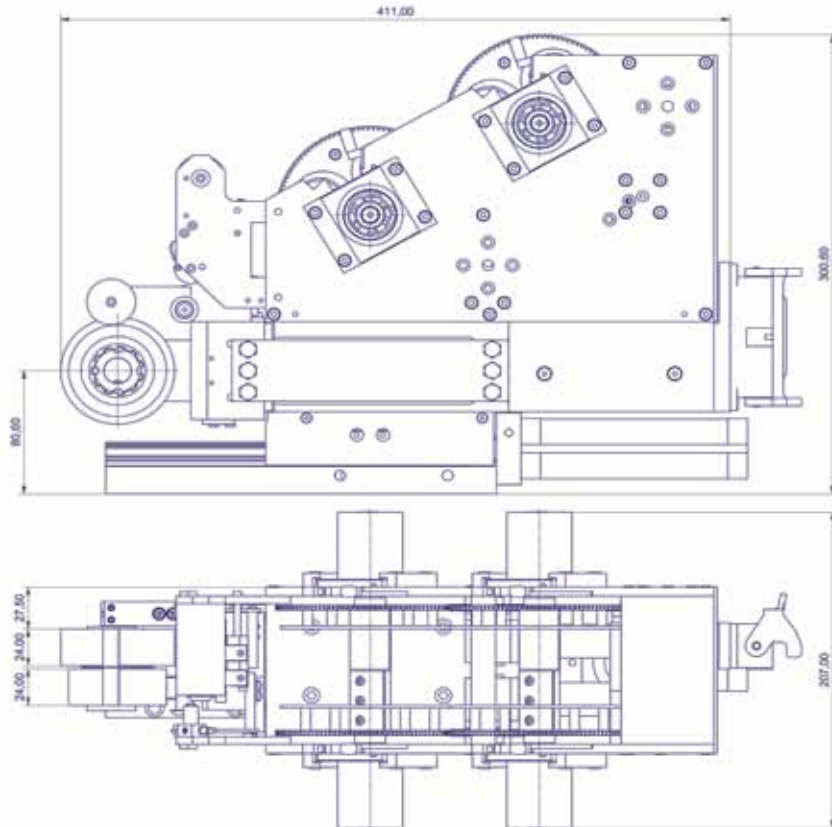
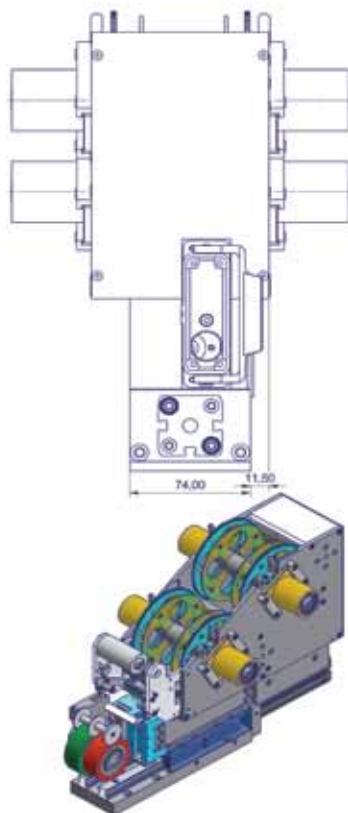

**SUPERFINISH – a company of Thielenhaus Technologies**

**UK & Ireland Agent**

**MASTER**  
**ABRASIVES**

Phone: 01327 703813  
 Email: sales@master-abrasives.co.uk  
 www.master-abrasives.co.uk



Superfinish Innovation AG  
 St. Gallerstrasse 52  
 CH-9548 Matzingen  
 Phone: +41 (0)52 376 26 20  
 info@superfinish.ch  
 www.superfinish.ch