

SUPERFINISH

INNOVATION

μ

modular • flexible • economical • universal

Stonefinisher SF70

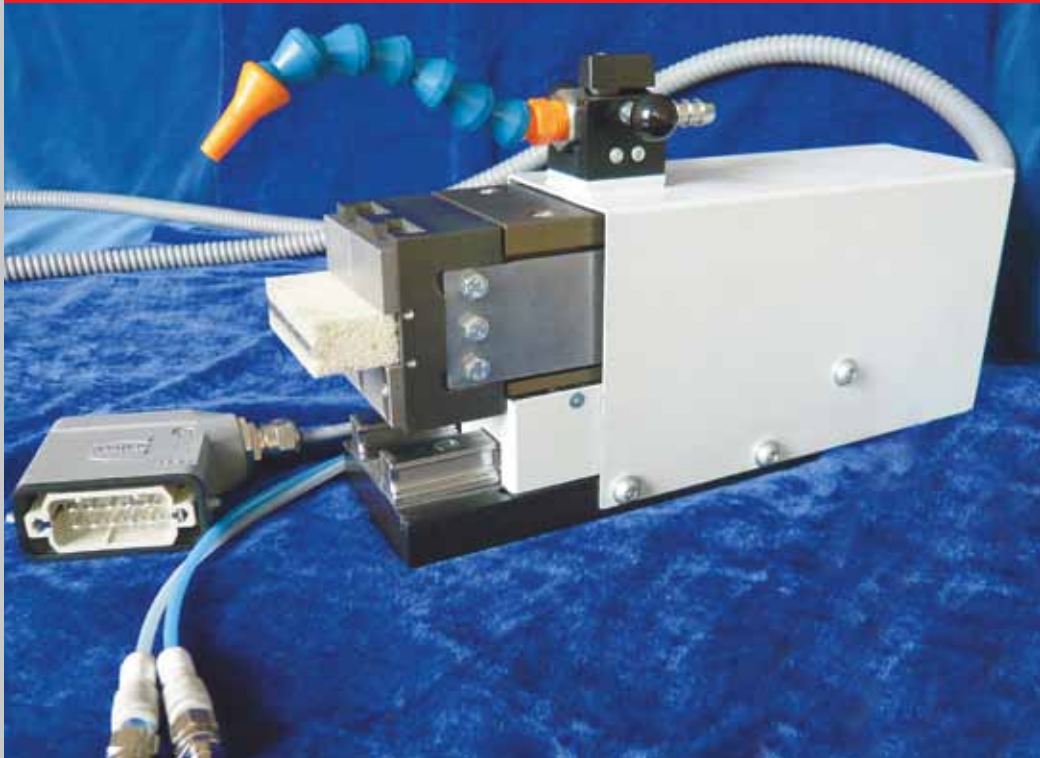

Technology-benefits

The optimized surface produces less friction and therefore improves the abrasion, the durability, the noise development and the energy expenditure.

This kind of surfaceimprovement is simple compared to other principles, process-safe and economical.

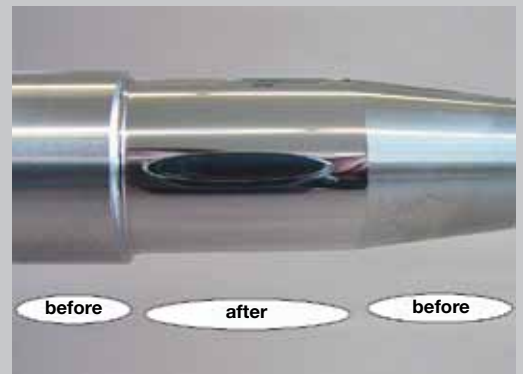

SBM control box manual
for manual finishing of individual parts and small series



SBA control box automatic
for time-regulated cut-in-finishing of individual parts and small series

Stonefinisher SF70 – Technical datas

Oscillation rate:	300–2000 strokes/min.
Oscillation path:	Standard +/- 1 mm optional: +/- 0,5; +/- 1,5; +/- 2 mm
Pressing-on move:	Standard 40 mm optional: 70, 100 mm
Pressing-on force:	80–480 N (1–6 bar)
Stone width:	max. 70 mm
Stone height:	3–28 mm, clampable
Control voltage:	24 VDC
Weight:	9,3 kg

Adaptors

Elektric:	100–260 VAC, 50/60 Hz, 6 A (L, N, PE)
Pneumatic:	1 x 6 bar



Options

- Machine device for direct assembly with sensors
- Special Stoneholders

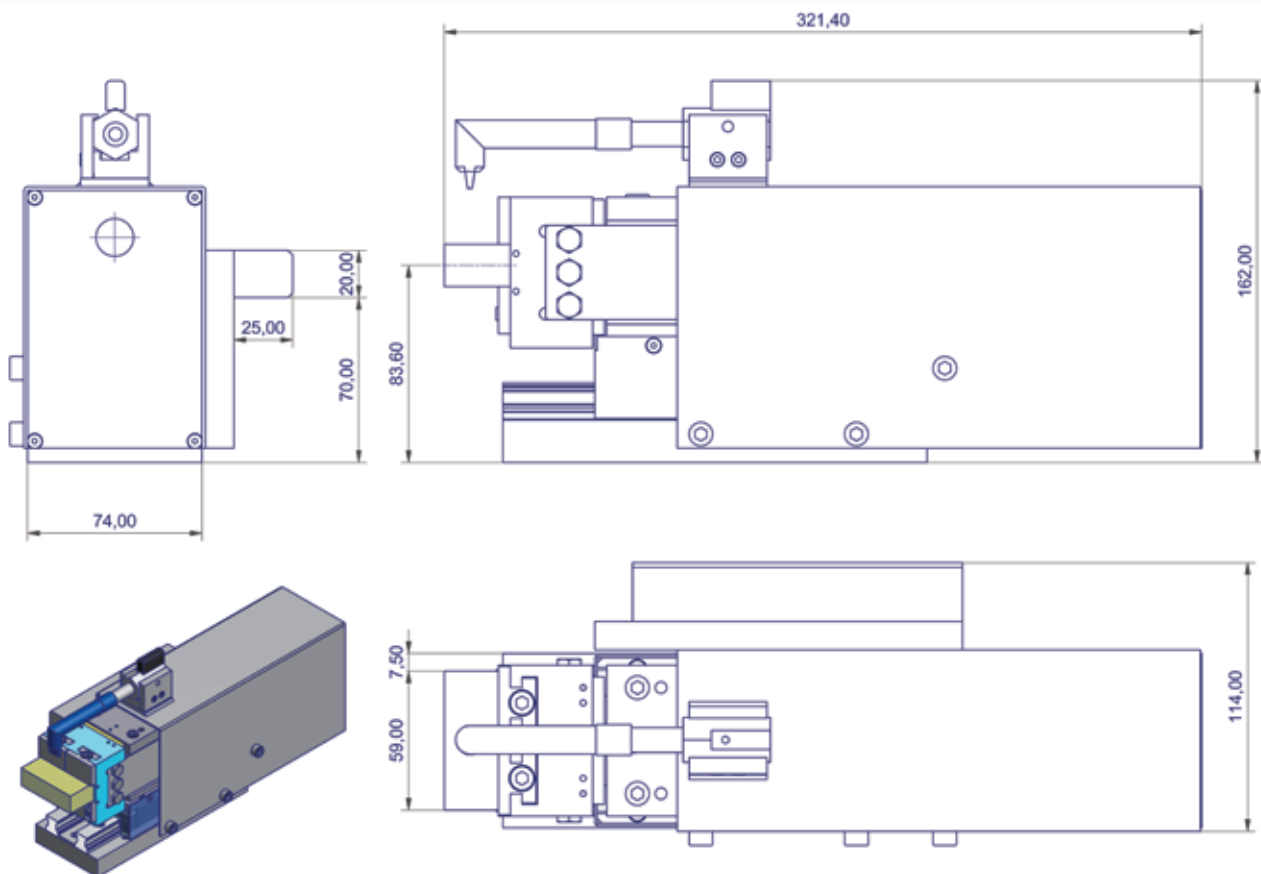

SUPERFINISH – a company of Thielenhaus Technologies

UK & Ireland Agent

MASTER
ABRASIVES

Phone: 01327 703813
 Email: sales@master-abrasives.co.uk
 www.master-abrasives.co.uk



Superfinish Innovation AG
 St. Gallerstrasse 52
 CH-9548 Matzingen
 Phone: +41 (0)52 376 26 20
 info@superfinish.ch
 www.superfinish.ch